

DP062F

Air dehumidifiers for industrial processes



Many configurations

Casing in stainless steel double skin

High performance desiccant rotor

Simple maintenance

High efficiency fans with EC motor

Programmable logic controller (PLC) with integrated controls (humidity, temperature and air flow)



DP062F technical specifications

Dry air flow range :	from 1000 to 4000 m³/h
Wet air flow :	675 m³/h
Electrical power :	20,25 kW

Capacity diagram

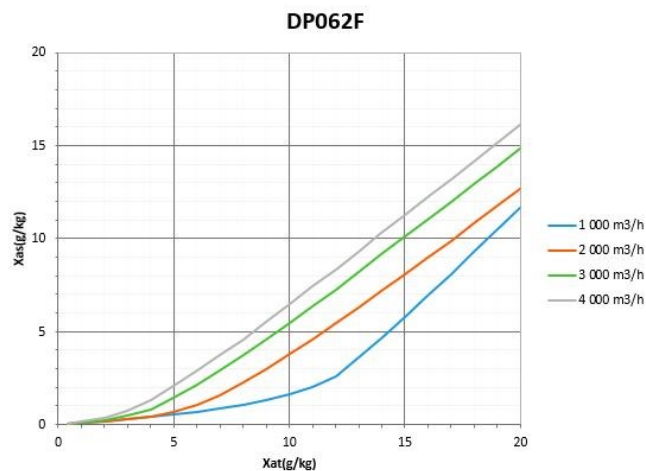

Example :

T_AT = Process air temperature

T_AS = Dry air temperature

DP062F : $T_{AS} = T_e + \Delta x * 3,3 \pm 8000 / Q_v$

References

DP062	F	D	5	0	0	B	0	G
Range DP : Product type 062 : 630x200mm	Reactivation power F : 20,25kW	Process air fan configuration 0 : Without AF D : 1,0kW E : 1,9kW S : 2 x 1,0kW T : 2 x 1,9kW	Filtration configuration 0 : G4 React 1 : F8 React 2 : F9 React 3 : G4/F8 React 4 : G4/F9 React 5 : G4 6 : F8 7 : F9 8 : G4/F8 9 : G4/F9	Electrical configuration 0 : Basic 1 : 4th PIDc* 2 : 5th PIDc* 3 : Basic + PF 4 : 4th PIDc* + FP 5 : 5th PIDc* + FP	Blocks configuration 0 : Without blocks M : Upstream block V : Downstream block B : Up and downstream blocks	Power supply mode B : 3P + N + T C : 3P + T	Reactivation utility 0 : Electricity 2 : Steam 4 : Gas 6 : Hot water	Easement G : Left D : Right

AF : Air fan
 PIDc : Configurable PID control
 FP : Filter pressure switch
 Basic : 3 PID control (humidity, process & reactivation air flows)

Dimensions

Left site

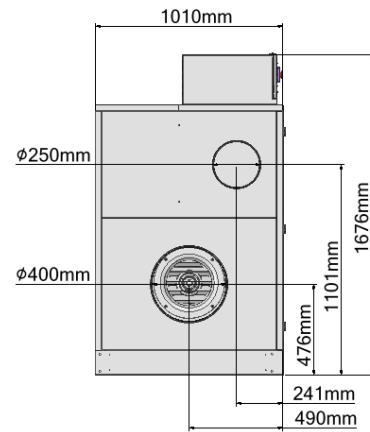
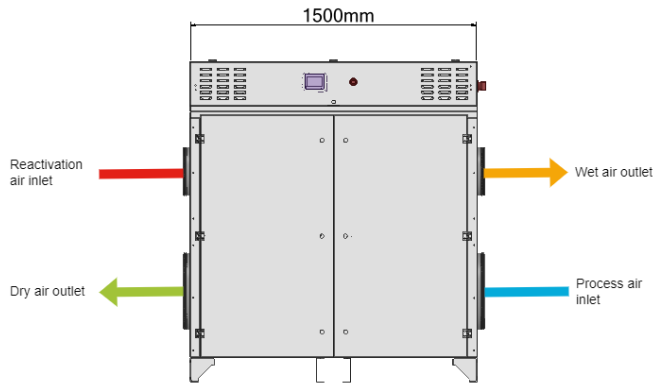

Right side

